

PARTS LIST

P/L No. 46014-510-00

REF. No.	PARTS No.	PARTS NAME	ROLLER		1/2	RECOMM.(%) Lot.100	REMARKS
			Q'TY INCLUDING	PRICE()			
1	36099 102	ROLLER(L)	1				
2	36099 103	ROLLER(R)	1				
3	61024 118	SPACER	0~2				
4	664V 0016	WAVE SPRING WASHER	0~2				
5	91020 131	KEY	1				
6	68013 265	SPRING	1				
7	36065 444	COVER	1				
8	36065 445	COVER	1				
9	342L 0616	FLANGE TAPPING BOLT	2				
10							
11							
12							
13							
14							
15							
16							
17							
18	475L 0516	(+)TAPPING SCREW	4				
19	31057 181	HEXAGON BOLT	1				
20							
21	11113 411	STAY(RL)	1				
22	11113 412	STAY(RR)	1				
23	342L 0612	FLANGE BOLT TAPPING	2				
24	31057 261	HEXAGON BOLT	2				
25	569L 0800	FLANGE NYLON NUT	2				
26	11142 136	ADJUSTER(L)	1				
27							
28							
29							
30	11142 137	ADJUSTER(R)	1				

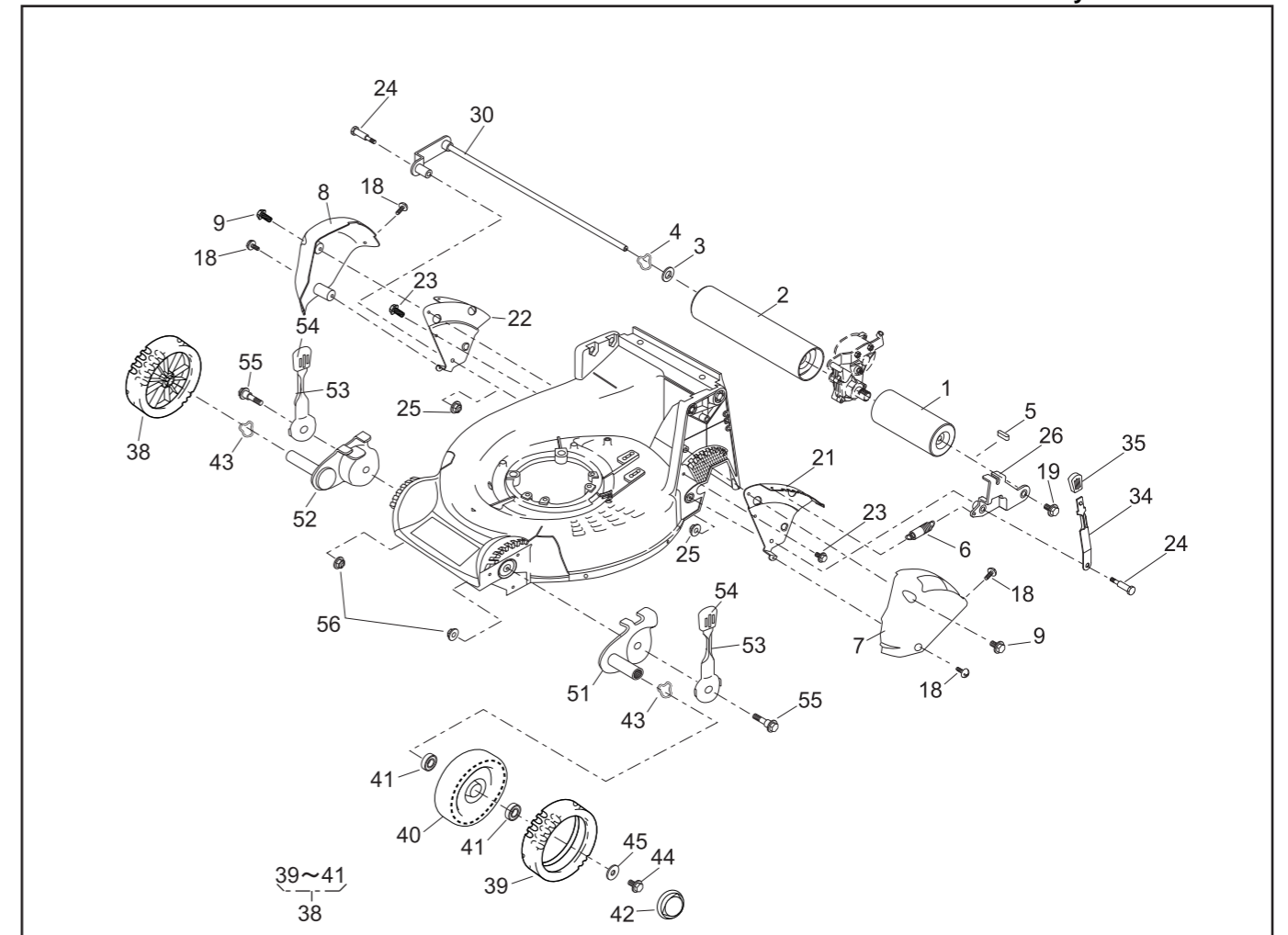

PARTS LIST

P/L No. 46014-510-00

REF. No.	PARTS No.	PARTS NAME	ROLLER		2/2	RECOMM.(%) Lot.100	REMARKS
			Q'TY INCLUDING	PRICE()			
31							
32							
33							
34	11150 108 09	ADJUST LEVER	1				
35	36061 121	KNOB	1				
36							
37							
38	71041 103	WHEEL ASSY	2				
39	91086 106	TIRE	2				
40	36107 102	WHEEL	2				
41	932L 0696	BEARING	4				
42	36070 110	CAP	2				
43	664V 0626	WAVE SPRING WASHER	2				
44	31057 181	HEXAGON BOLT	2				
45	68036 101	WASHER	2				
46							
47							
48							
49							
50							
51	11142 138	ADJUSTER(FL)	1				
52	11142 139	ADJUSTER(FR)	1				
53	11150 107 09	ADJUST LEVER	2				
54	36061 121	KNOB	2				
55	31057 260	HEXAGON BOLT	2				
56	569L 0800	FLANGE NYLON NUT	2				
57							
58							
59							
60							