

PARTS LIST

P/L No. 46014-511-00

REF. No.	PARTS No.	PARTS NAME	8"AI-ROLLER		1/2	RECOMM.(%) Lot.100	REMARKS
			Q'TY INCLUDING	PRICE( )			
1	36099   102	ROLLER(L)	1				
2	36099   103	ROLLER(R)	1				
3	61024   118	SPACER	0~2				
4	664V   0016	WAVE SPRING WASHER	0~2				
5	91020   131	KEY	1				
6	68013   265	SPRING	1				
7	36065   444	COVER	1				
8	36065   445	COVER	1				
9	342L   0616	FLANGE TAPPING BOLT	2				
10							
11							
12							
13							
14							
15							
16							
17							
18	475L   0516	(+)TAPPING SCREW	4				
19	31057   181	HEXAGON BOLT	1				
20							
21	11113   411	STAY(RL)	1				
22	11113   412	STAY(RR)	1				
23	342L   0612	FLANGE BOLT TAPPING	2				
24	31057   261	HEXAGON BOLT	2				
25	569L   0800	FLANGE NYLON NUT	2				
26	11142   136	ADJUSTER(L)	1				
27							
28							
29							
30	11142   137	ADJUSTER(R)	1				

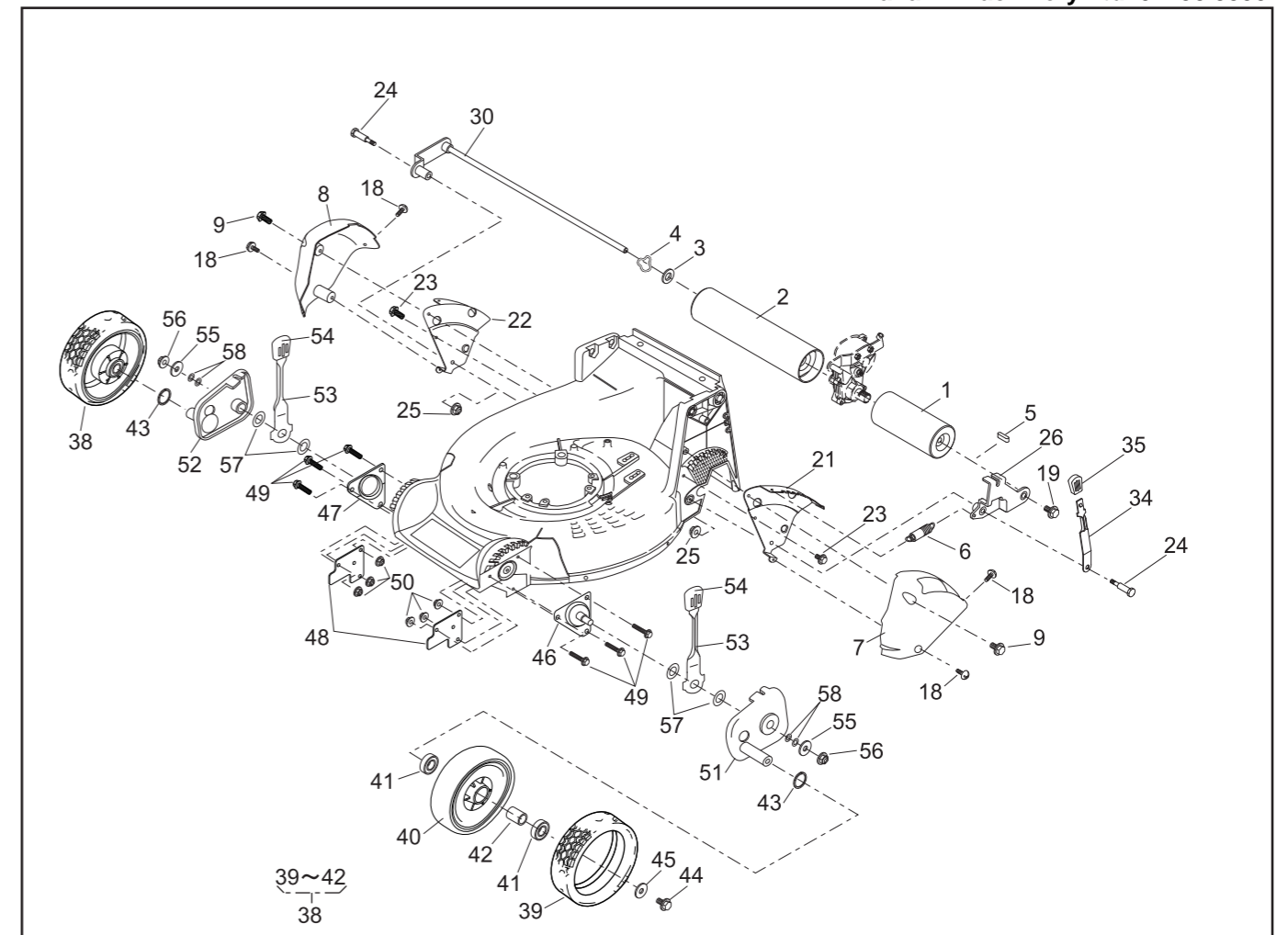

PARTS LIST

P/L No. 46014-511-00

REF. No.	PARTS No.	PARTS NAME	8"AI-ROLLER		2/2	RECOMM.(%) Lot.100	REMARKS
			Q'TY INCLUDING	PRICE( )			
31							
32							
33							
34	11150   108   09	ADJUST LEVER	1				
35	36061   121	KNOB	1				
36							
37							
38	71041   135	WHEEL ASSY(A.W.)	2				
39	91086   113	TIRE	2				
40		WHEEL	2				
41	916B   6002	BEARING	4				
42	11083   332	COLLAR	2				
43	51113   119	RING	2				
44	31057   181	HEXAGON BOLT	2				
45	68036   101	WASHER	2				
46	11006   153	STAY C.P.(FL)	1				
47	11006   154	STAY C.P.(FR)	1				
48	11113   409	STAY	2				
49	335L   0625	FLANGE BOLT	6				
50	569L   0600	FLANGE NYLON NUT	6				
51	11142   129	ADJUSTER(FL)	1				
52	11142   130	ADJUSTER(FR)	1				
53	11150   109   09	ADJUST LEVER	2				
54	36061   121	KNOB	2				
55	68036   101	WASHER	2				
56	584L   0800	U-FLANGE NUT	2				
57	68013   393	SPRING	4				
58	68007   105	SHIM	0~4				
59							
60							